



# AUTOMATIC PENALTY CHARGING FOR VIOLATION OF TRAFFIC RULES

Aditi Dambe<sup>1</sup>, Upasana Gandhe<sup>2</sup>, Varsha Bendre<sup>3</sup>

Student, Dept.-E&TC, Pimpri Chinchwad College of Engineering, Pune, Maharashtra, India<sup>1</sup>

Student, Dept.-E&TC, Pimpri Chinchwad College of Engineering, Pune, Maharashtra, India<sup>2</sup>

Professor, Dept.-E&TC, Pimpri Chinchwad College of Engineering, Pune, Maharashtra, India<sup>3</sup>

**Abstract:** During the past few years, traffic accidents & congestion has increased enormously. Even in our daily life, we come across many problems caused due to traffic rule violation by some people. Also when we go through the daily newspaper, we realize that road accidents is one of the major problems now a days in every city. These problems cause disturbance to the whole system and also consumes our precious time. So in an attempt to reduce it & improve the traffic discipline, advanced technological solutions has been proposed. In this project, we are designing a system which will automatically incur penalty to the car driver for violation of traffic rules. The penalty will be automatically charged to the car owner if PUC has been expired or if car is standing on zebra crossing when the signal is red, for illegal signal crossing, crossing the speed limit in speed limit zone or parking the car in no parking zone. Also the car will not start if the driver does not have license or if he is drunk. This will help to bring discipline on roads.

**Keywords:** AVR microcontroller to control all operations; RFID; LCD interfaced with AVR; Penalty; Traffic; Violation

## I. INTRODUCTION

In the past few years, traffic accidents & congestions have increased enormously. Though the vehicle volume has increased exponentially, the road infrastructure has not been improved proportionately. This in turn leads to increased traffic congestion and road accidents. Different technologies are there to detect traffic congestion and to make congestion management more efficient, but these technologies have several drawbacks, such as installation problems, complexity, cost, etc. In an attempt to reduce the problems related to traffic & improve the traffic discipline, advanced technological solutions have been proposed in this paper.

Through this project we are aiming to provide a system, which will continuously monitor the vehicles using RFID reader and RFID transceivers and automatically incur penalty for violation of any of the traffic rules. If a driver violates any of the traffic rules, the driver will be charged according to the RTO rules. The charging amount will be automatically stored in a smart card which will be fixed in the vehicle. If a driver fails to pay the charges in a given period of time, his/her license will be suspended and the car won't start. Thus in this project, we are to some extent compelling people to follow the traffic rules. This will definitely reduce the problems to some extent.

The ministry of heavy industries is considering a proposal to make it mandatory to fit RFID-enabled devices in the cars manufactured in India. It is believed that RFID tags would help in traffic management as traffic violations by motorists could be tracked and all violations identified. Also, motorists would get charged automatically as soon as they enter a toll area. Taking into consideration this strategy, we are introducing our paper. The ministry of urban development has already discussed a similar agenda with many states. The ministry has proposed a core area charge for different cities to reduce traffic congestion in the city's nerve centre. So, people could end up paying a special levy to drive into Connaught Circus, the heart of the Capital. In Singapore, public transport buses and trains employ RFID cards known as EZ-Link cards. Traffic into crowded downtown areas is regulated by variable tolls imposed using an active tagging system combined with the use of stored-value cards (known as cash cards). RFID is also used in Malaysia Expressways payment system, known as Touch n Go. Due to the name and design, the card needs to be touched for usage. With an eye to improving traffic management and information access, the Orlando/Orange County Expressway Authority (OOCEA) is deploying an RFID-based traffic-monitoring system in central Florida. Automatic Billing of Penalty Charges is also there but it is only for selected Traffic Rule Violations such as speed limit violation and entry into congested area in spite of re-routing messaging. But in our project we are trying to incur penalty for almost all the traffic rule violations.

## II. LITERATURE SURVEY

Some of the available technologies are Inductive loop detection, Video data analysis, Passive infrared sensors, Wireless sensor network and Radio frequency Identification.



A. *Inductive loop detection*: It can be placed in a roadbed to detect vehicles by measuring the vehicle's magnetic field. The simplest detectors simply count the number of vehicles during a unit of time. Loops can be placed in a single lane or across multiple lanes.

B. *Video Data Analysis*: Video feeds from the cameras. The built-in software harvests information from that video. Information (Vehicle volume, average velocity etc.) then fed into the fuzzy system. That outputs the level of traffic congestion.

C. *Passive Infrared sensors*: Passive sensors detect energy emitted from vehicles, road surfaces and other objects in their field of view and by the atmosphere. The captured energy is focused by an optical system onto an infrared-sensitive material which converts the reflected energy into electrical signals. Real-time signal processor analyse the signals to detect presence of a vehicle.

D. *Wireless Sensor Network*: Magnetic sensors are deployed by the road intersection to detect vehicles. The sensors send the collected data to the Intersection Control Agent (ICA). ICA process the data and dynamically controlled the traffic light. A high vehicle density in a particular lane causes a traffic signal in that particular direction to remain open for larger duration thus adaptively controlling the signal.

E. *Radio Frequency Identification (RFID)*: Radio-frequency identification (RFID) is a technology that use for the purpose of identification and tracking using radio waves. Most RFID tags contain at least two parts. One is an integrated circuit for storing and processing information, modulating and demodulating a radio frequency (RF) signal and other specialized functions. The second is an antenna for receiving and transmitting the signal. There are two types of RFID devices: Active RFID device contain a battery and can transmit signals autonomously and Passive RFID devices have no battery and require an external source to provoke signal transmission.

### III. BLOCK DIAGRAM

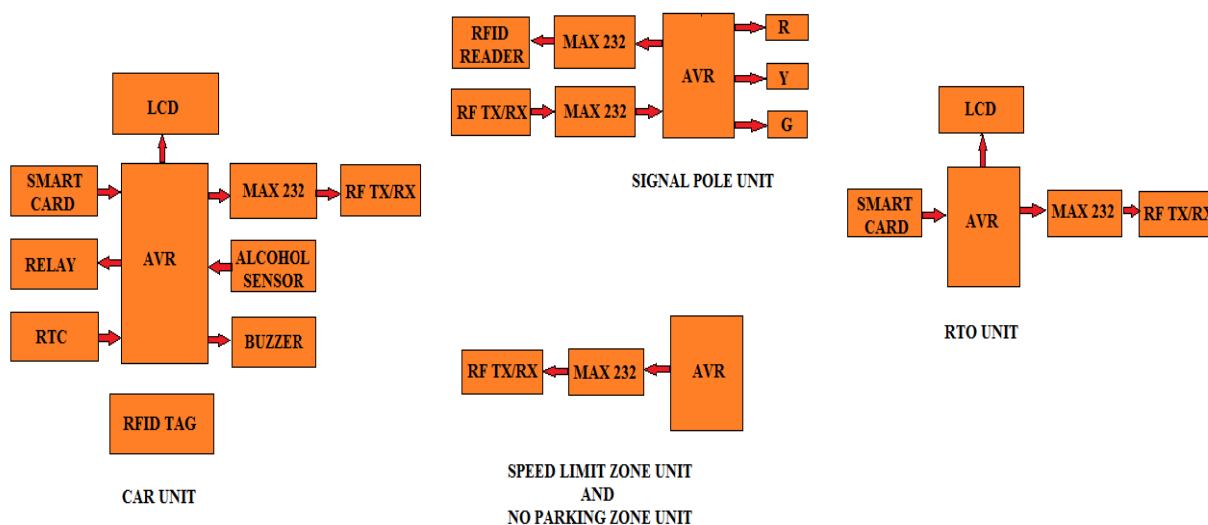

Fig 1:- Block Diagram of project

There are four units in this project. One: A system attached to the ignition mechanism of the car, Second: A System attached to the traffic signal point, Third: A system will be at the speed limit zones and no parking zones and Fourth: A system will be at the RTO unit.

For car ignition the driver has to insert his smart card in the car unit smart card slot. If any document (e.g. PUC, license) is expired or smart card is not inserted, then car won't start and the reason will be displayed on the LCD screen. Thus, carrying the smart card with you is mandatory. After checking all the details of the driver, the system will go for alcohol detection. The user has to blow air near the alcohol sensor present in car unit. If the content of alcohol in human breath is found to be more than the set threshold then the ignition of the car will not be triggered. This prevents drunk driving and accidents caused due to it. In the car unit we are using AVR Microcontroller which will control all the operations. Smart card is used for storing car details like driver's license number, PUC, expiry dates of both as well as the number of penalties that has been charged to that driver. We have used EEPROM as a smart card to store all these details. The ARM Microcontroller will check these car details, if all the data is as required then only the car ignition is allowed. RF module is attached to the AVR Microcontroller. RF module will continuously transmit car details stored in smart card and also the RPM which will indicate the speed of the car. This RF module communicates with AVR through serial communication; for that MAX 232 IC and RS 232 cable has been used. Relay has been used to control the ignition of the car. Real time clock (RTC) is used to provide precise date and time for the expiry of PUC



and license. For the convenience of the user LCD is used to display all the information about the penalties and other required details. The buzzer will ring after each penalty is charged to indicate the driver. At the traffic signals there will be RFID reader attached to the AVR Microcontroller at the signal pole. RFID reader will detect the RFID TAG of the car which has crossed the road when the signal is red. The RFID TAG is attached at the bottom of each car, with each TAG having its own different identity. Warning will be issued to the driver by sending message to the car unit and penalty will be charged to that particular driver's smart card only. At the speed limit zone and no parking zone also there are RF transceivers. The speed limit is saved in AVR microcontroller at the speed limit zone which will be continuously transmitted by the RF module attached to the microcontroller. If the speed of the car is more, then penalty will get charged. Again in the no parking zone also there is one RF module, if it receives the RF waves 10 times then it is considered that the car is parked and penalty will be charged to that car.

After each penalty is charged the microcontroller increases the penalty count and stores it in smart card. There will be a penalty limit (it is 4 in this case) which if crossed, the car won't start. We have provided one emergency switch to start the car even after crossing the maximum penalty limit. But with emergency switch, the car can only travel some specified distance and then ignition will again switch off and then it won't switch on until the driver clears his smart card at the RTO. To pay the penalty and to clear his smart card, car owner must go to the authorized RTO centre with his smart card. Our RTO unit is interfaced serially with the computer. At the RTO centre, there is also one smart card slot where you need to insert your smart card. Microcontroller will then scan the smart card and accordingly the penalty count will be displayed on the LCD screen. The RTO officer will then nullify the penalty by issuing a command through keyboard.

#### IV. CONCLUSION

In this way we have come up with an implementation of a system which will automatically incur penalty for violation of traffic rules and in turn will lead to a disciplined traffic in our country. We hope these efforts will help in minimizing many problems related to traffic which brings disturbance to the whole system and will help in reducing number of accidents; traffic jam which consumes our precious time, and will also reduce pollution to some extent.

In our system we are monitoring the traffic only at the signal poles but it could also be useful in monitoring the no entry area, one way routes etc. Also in this system a driver needs to go to the RTO centre for paying the penalty amount he/she has been charged. Instead of this we can provide other modes of payment like an online payment mode, mobile payment, pay by mail to the users which is time saving and quick.

#### V. REFERENCES

- [1] Cherrett, T., Waterson, B. and McDonald, M. (2005) "Remote automatic incident detection using inductive loops". Proceedings of the Institution of Civil Engineers: Transport, 158, (3), 149-155.
- [2] Palubinskas, G., Kurz, F. and Reinartz, P. (2009) "Traffic congestion parameter estimation in time series of airborne optical remote sensing images". In: Proc. of ISPRS Hannover Workshop 2009 – High Resolution Earth Imaging for Geospatial Information, 2-5 June, 2009, Hannover, Germany, ISPRS.
- [3] Palubinskas, Gintautas and Kurz, Franz and Reinartz, Peter (2008) "Detection of traffic congestion in optical remote sensing imagery". In: International Geoscience and Remote Sensing Symposium . IEEE . IGARSS08 , 2008-07-06 - 2008-07-11 , Boston, USA.
- [4] P. Pongpaibool, P. Tangamchit and K. Noodwong, "Evaluation of Road Traffic Congestion Using Fuzzy Techniques". Proceeding of IEEE TENCON 2007, Taipei, Taiwan, October 2007.
- [5] Agilent Intelligent Traffic Video Detection Workstation Data Sheet. (<http://cp.literature.agilent.com/litweb/pdf/5990-4034EN.pdf>)
- [6] Traffic Detector Handbook: Third Edition Volume I (<http://www.tfrc.gov/its/pubs/06108/02a.htm>)

#### BIOGRAPHY



Aditi Dambe, She is perceiving her B.E. Degree in Electronics & Telecommunication Engineering in Pimpri Chinchwad College of Engineering, Pune.



Upasana Gandhe, She is perceiving her B.E. Degree in Electronics & Telecommunication Engineering in Pimpri Chinchwad College of Engineering, Pune.



Varsha Bendre is an Assistant Professor in Electronics and Telecommunication Department at Pimpri Chinchwad College of Engineering, Pune. She received her B.E. degree from Amravati University and M.E. degree from University of Pune in 2000 and 2011 respectively. She is been teaching for about 9 years. Her research interests include VLSI Design and Signal Processing